

NOTE!!

I'VE DRAWN THE SAMPLE KNEE WALL WITH A 1" CLEARANCE FOR CASIER BLOCKS TO BE USED.

THE FINISHED HEIGHT MUST EQUAL THE FINISHED HEIGHT INDICATED ON THE CRESCENT PLAN!!

SUGGESTED SUPPORT METHOD FOR CRESCENT

ANGLE TOP SUPPORT BY 1/4" TO ALLOW FOR RAKE

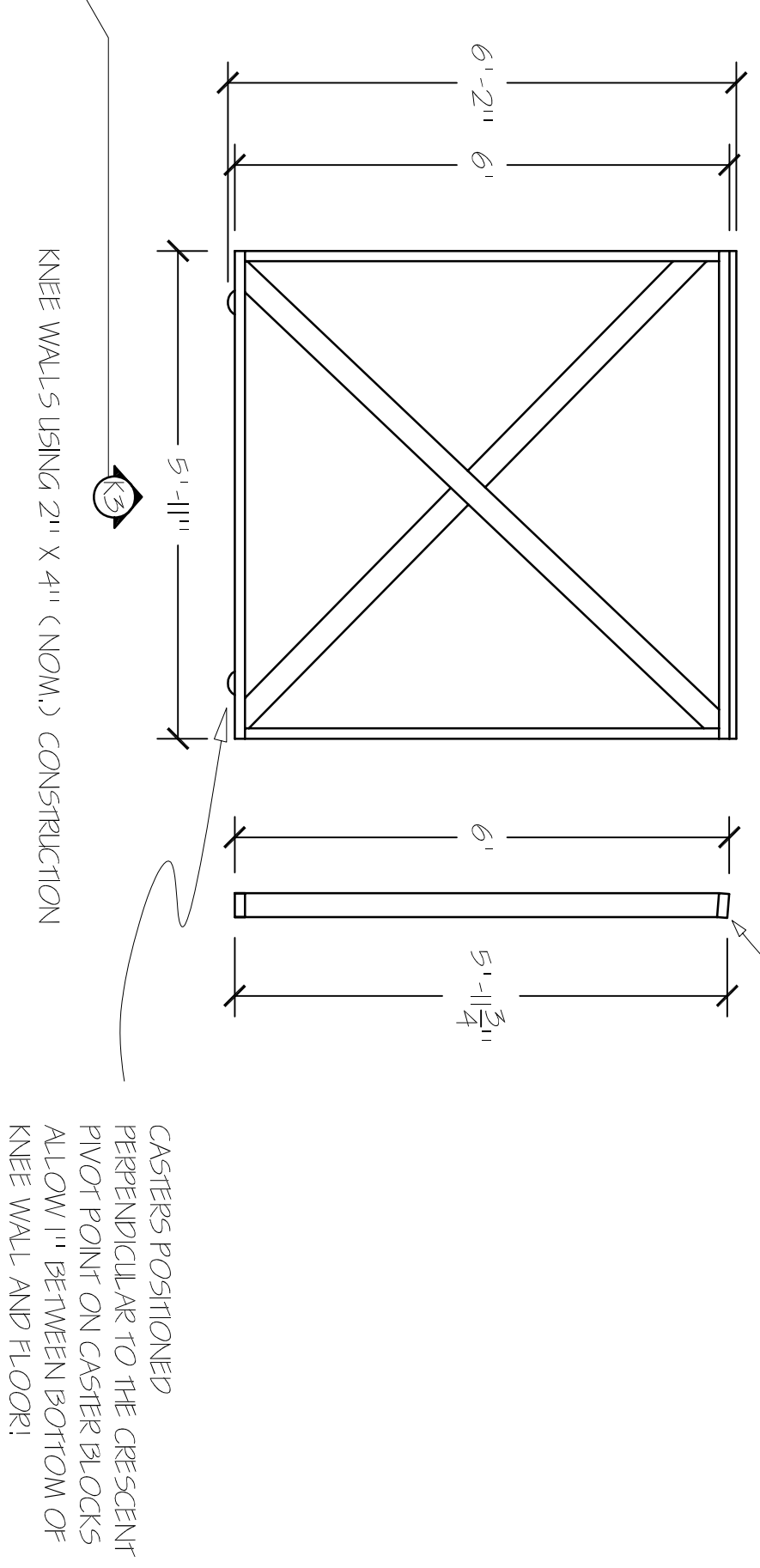

CASIERS POSITIONED PERPENDICULAR TO THE CRESCENT PIVOT POINT ON CASIER BLOCKS ALLOW 1\"/>

CONSTRUCTION SUGGESTIONS:

- THE DECK OF THE CRESCENT SHOULD CONSIST OF 3 LAYERS OF 1/4" PLYWOOD LAMINATED TOGETHER TO CREATE THE RAKE.
- THE FINAL TOP LAYER SHOULD BE 1/4" TEMPERED MASONITE
- THE KNEE WALLS SHOULD BE 1" SHORTER THAN THE FINISHED HEIGHT INDICATES (SEE SAMPLE KNEE WALL DRAWING)
- THE LOCATION OF THE "SEDETT" DOORS MAY ALTER THE PLACEMENT OF THE KNEE WALLS

LOOSE PIN HINCE BOTH STAIR UNITS TO CRESCENT THEY BOTH ARE REMOVED DURING THE SHOW COVER THE ENDS OF THE CRESCENT WITH LUMI SO THE AUDIENCE CANNOT SEE INTO THE ENDS OF THE CRESCENT

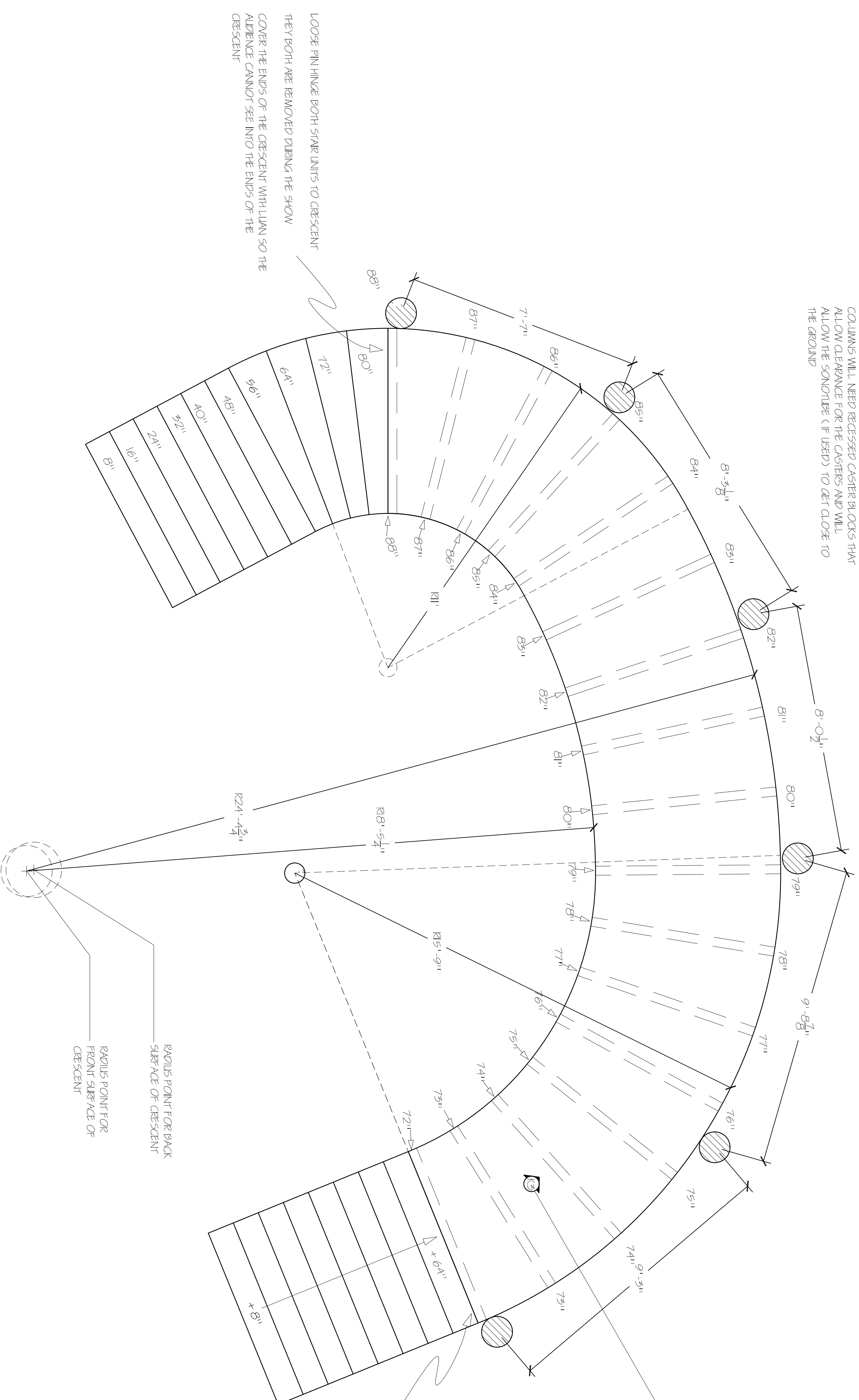

COLUMNS WILL NEED RECESSED CASIER BLOCKS THAT ALLOW CLEARANCE FOR THE CASIERS AND WILL ALLOW THE SONOTUBE (IF USED) TO GET CLOSE TO THE GROUND

RADIUS POINT FOR BACK SURFACE OF CRESCENT

RADIUS POINT FOR FRONT SURFACE OF CRESCENT

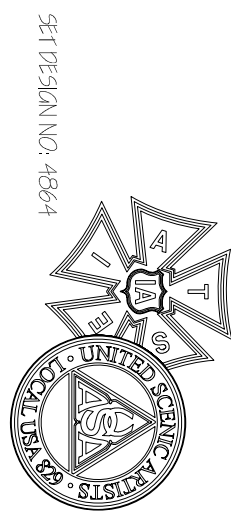

SET DESIGN NO. 4864
5/16/06

THE MUNKY
10251 PARK
PO BOX 1074
ST. LOUIS, MO 63112-1098
914-561-1900 EXT. 550 BOX OFFICE
WWW.MUNKY.ORG

Elton John and Tim Rice's
AIDA

Executive Producer: Paul Blake
Production Director: Matt Lantz
Choreographer: Darren Lee
Set Designer: Steve Gilliam
Costume Designer: Mich Dana
Lighting Designer: Mich Dana
Production Stage Manager:

SCENIC DESIGNER:
STEVE GILLIAM & SAM CARTER GILLIAM
UNITED SCENIC ARTIST LOCAL 832
540 RESHAW AND CREATIVE TALENT
210-494-7375

SCALE: 1/2" = 1'-0"
DATE: APRIL 24, 2006
TD:

ASSISTANT DESIGNER & DRAFTSMAN:
Michael J. Rhea
2297 Park Ave
Fayetteville, NC 27804
419-531-6023 cell 419-466-6979
mjrhea@aol.com

REVISION: 649-06
PAGE NO. **OF 16**